



Expansion module with output contacts

Main features

- For safety applications up to SIL CL 3/PL e
- Possibility of control with one or two channels
- Connection of input channels of opposite potentials
- Reduced housing width of 22.5 mm
- Output contacts:
 - 5 NO safety contacts,
 - 1 NC auxiliary contact,
 - 1 NC feedback contact
- Supply voltage: 24 Vac/dc

Utilization categories

Alternating current: AC15 (50...60 Hz)

U_e (V) 230

I_e (A) 3

Direct current: DC13 (6 oper. cycles/min.)

U_e (V) 24

I_e (A) 4

Quality marks and certificates:



EC type examination certificate: IMQ CP 432 DM

UL approval: E131787

CCC approval: 2013010305640211

EAC approval: RU C-IT.AJ35.B.00454

Compliance with the requirements of:

Low Voltage Directive 2014/35/EU,

Machinery Directive 2006/42/EC,

EMC Directive 2014/30/EU

Technical data

Housing

Polyamide housing PA 66, self-extinguishing V0 acc. to UL 94

Protection degree:

IP40 (housing), IP20 (terminal strip)

Dimensions:

see page 295, design A

General data

SIL CL:

up to SIL CL 3 acc. to EN 62061

Performance Level (PL):

up to PL e acc. to EN ISO 13849-1

Safety category:

up to cat. 4 acc. to EN ISO 13849-1

(see base module category)

Safety parameters:

see page 349

Ambient temperature:

-25°C...+55°C

Mechanical endurance:

>10 million operating cycles

Electrical endurance:

>100,000 operating cycles

Pollution degree:

external 3, internal 2

Impulse withstand voltage (U_{imp}):

4 kV

Rated insulation voltage (U_i):

250 V

Overvoltage category:

II

Weight:

0.3 kg

Supply

Rated supply voltage (U_n):

24 Vac/dc; 50...60 Hz

Max. DC residual ripple in DC:

10%

Supply voltage tolerance:

±15% of U_n

Power consumption AC:

< 5 VA

Power consumption DC:

< 2 W

Control circuit

Protection against short circuits:

PTC resistance, I_h=0.5 A

PTC times:

Response time > 100 ms, release time > 3 s

Maximum resistance per input:

≤ 50 Ω

Response time t_r:

< 40 ms

Release time in absence of power supply t_r:

< 50 ms

In compliance with standards:

EN 60204-1, EN ISO 13855, EN 1037, EN ISO 12100, EN ISO 13850, EN 60529,

EN 61000-6-2, EN 61000-6-3, EN 61326-1, EN 60664-1, EN 60947-1, EN ISO 13849-1,

EN ISO 13849-2, EN 62061, UL 508, CSA C22.2 n° 14-95

Output circuit

Output contacts:

5 NO safety contacts,

1 NC auxiliary contact,

1 NC feedback contact

Contact type:

forcibly guided

Material of the contacts:

gold-plated silver alloy

Maximum switching voltage:

230/240 Vac; 300 Vdc

Max. current per contact:

6 A

Conventional free air thermal current (I_{th}):

6 A

Max. total current Σ I_{th}²:

72 A²

Minimum current:

10 mA

Contact resistance:

≤ 100 mΩ

External protection fuse:

4 A

Code structure

CS ME-01V024

Connection type

V	Screw terminals
M	Connector with screw terminals
X	Connector with spring terminals

Supply voltage

024 24 Vac/dc

Stock items

CS ME-01V024

Features approved by UL

Rated supply voltage (U _n):	24 Vac/dc; 50...60 Hz
Power consumption AC:	< 5 VA
Power consumption DC:	< 2 W
Maximum switching voltage:	230 Vac
Max. current per contact:	6 A
Utilization category	C300

Notes:

- Use 60 or 75 °C copper (Cu) conductors, rigid or flexible, wire size 30-12 AWG.
- Tightening torque for terminal screws of 5-7 lb in.
- Only for 24 Vac/dc versions: power supply only with class 2 sources or with limited voltage and energy. (Supply from Remote Class 2 Source or limited voltage limited energy).



CS ME-01 expansion module

Pin assignment

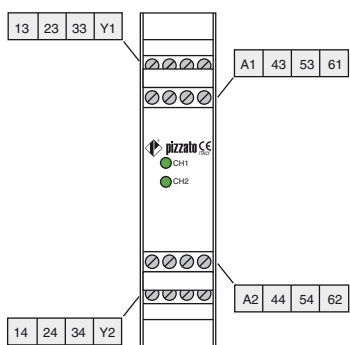

Function diagram

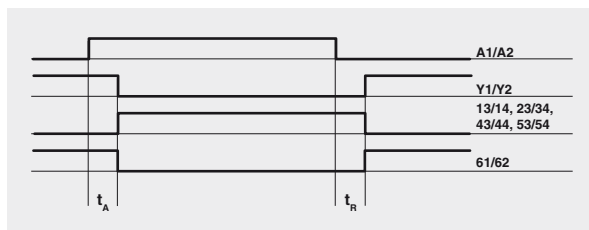

Legend:
 t_A : response time
 t_R : release time in absence of power supply

Internal block diagram

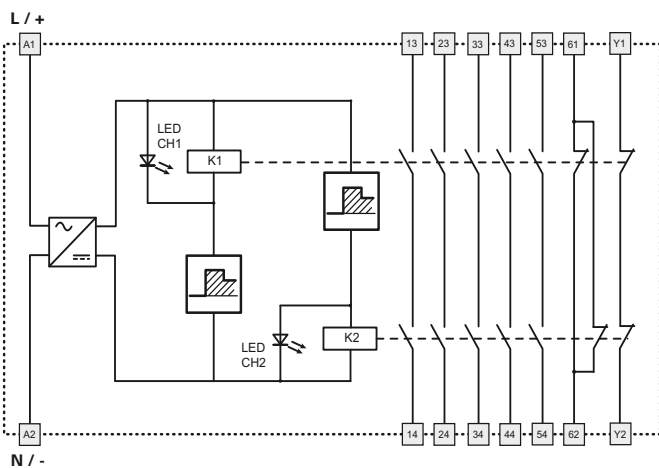

Input configuration

Single channel control

Double channel control

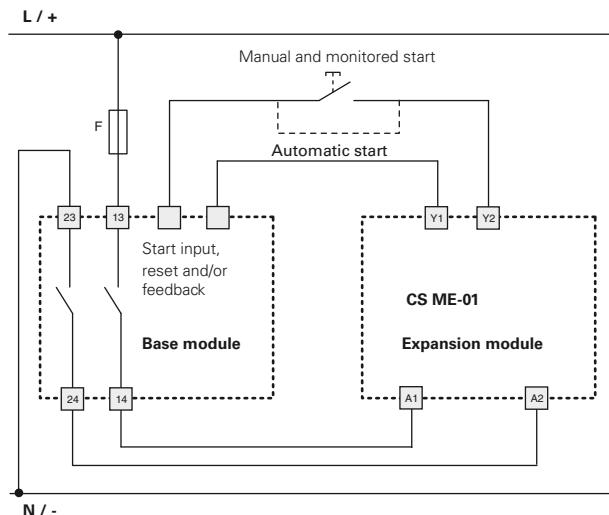
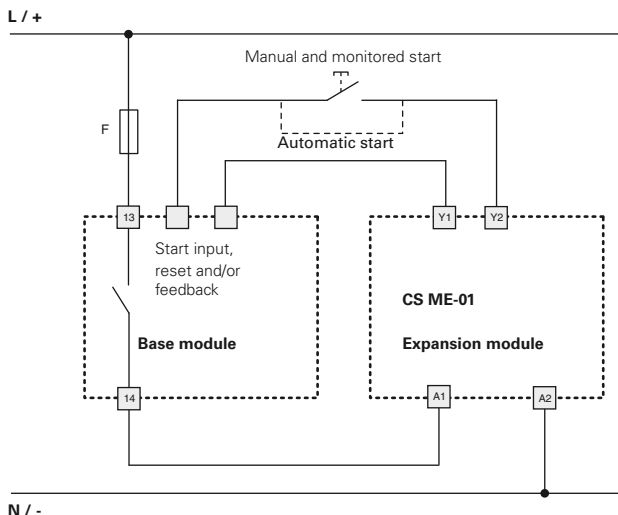

The diagram does not show the exact position of the terminals in the product

Items with code on **green** background are stock items



Expansion module with output contacts

Main features

- For safety applications up to SIL CL 3/PL e
- Possibility of control with one or two channels
- Connection of input channels of opposite potentials
- Reduced housing width of 22.5 mm
- Output contacts:
 - 4 NO safety contacts,
 - 2 NC auxiliary contacts,
 - 1 NC feedback contact
- Supply voltage: 24 Vdc

Utilization categories

Alternating current: AC15 (50...60 Hz)

U_e (V) 230

I_e (A) 3

Direct current: DC13 (6 oper. cycles/min.)

U_e (V) 24

I_e (A) 4

Quality marks and certificates:



EC type examination certificate: IMQ CP 432 DM

UL approval: E131787

CCC approval: 2013010305640211

EAC approval: RU C-IT.AJ35.B.00454

Compliance with the requirements of:

Low Voltage Directive 2014/35/EU,

Machinery Directive 2006/42/EC,

EMC Directive 2014/30/EU

Technical data

Housing

Polyamide housing PA 66, self-extinguishing V0 acc. to UL 94

Protection degree:

IP40 (housing), IP20 (terminal strip)

Dimensions:

see page 295, design A

General data

SIL CL:

up to SIL CL 3 acc. to EN 62061

Performance Level (PL):

up to PL e acc. to EN ISO 13849-1

Safety category:

up to cat. 4 acc. to EN ISO 13849-1

(see base module category)

Safety parameters:

Ambient temperature:

see page 349

Mechanical endurance:

-25°C...+55°C

Electrical endurance:

>10 million operating cycles

Pollution degree:

>100,000 operating cycles

Impulse withstand voltage (U_{imp}):

external 3, internal 2

Rated insulation voltage (U_i):

4 kV

Overvoltage category:

250 V

Weight:

II

Supply

Rated supply voltage (U_n):

0.3 kg

Max. DC residual ripple in DC:

24 Vdc

Supply voltage tolerance:

10%

Power consumption DC:

±15% of U_n

< 2 W

Control circuit

Protection against short circuits:

PTC resistance, I_h=0.5 A

PTC times:

Response time > 100 ms, release

Maximum resistance per input:

time > 3 s

Response time t_d:

≤ 50 Ω

Release time in absence of power supply t_r:

< 100 ms

In compliance with standards:

EN 60204-1, EN ISO 13855, EN 1037, EN ISO 12100, EN ISO 13850, EN 60529,

EN 61000-6-2, EN 61000-6-3, EN 61326-1, EN 60664-1, EN 60947-1, EN ISO 13849-1,

EN ISO 13849-2, EN 62061, UL 508, CSA C22.2 n° 14-95

Output circuit

Output contacts:

4 NO safety contacts,

2 NC auxiliary contacts,

1 NC feedback contact

Contact type:

forcibly guided

Material of the contacts:

gold-plated silver alloy

Maximum switching voltage:

230/240 Vac; 300 Vdc

Max. current per contact:

6 A

Conventional free air thermal current (I_{th}):

6 A

Max. total current Σ I_{th}²:

64 A²

Minimum current:

10 mA

Contact resistance:

≤ 100 mΩ

External protection fuse:

4 A

Code structure

CS ME-02VU24

Connection type	
V	Screw terminals
M	Connector with screw terminals
X	Connector with spring terminals

Supply voltage	
U24	24 Vdc

Features approved by UL

Rated supply voltage (U _n):	24 Vdc
Power consumption DC:	< 2 W
Maximum switching voltage:	230 Vac
Max. current per contact:	6 A
Utilization category	C300

Notes:
 - Use 60 or 75 °C copper (Cu) conductors, rigid or flexible, wire size 30-12 AWG.
 - Tightening torque for terminal screws of 5-7 lb in.
 - Only for 24 Vac/dc versions: power supply only with class 2 sources or with limited voltage and energy. (Supply from Remote Class 2 Source or limited voltage limited energy).



CS ME-02 expansion module

Pin assignment

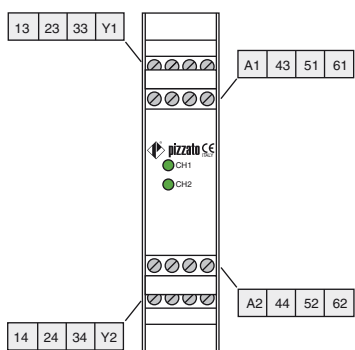

Function diagram

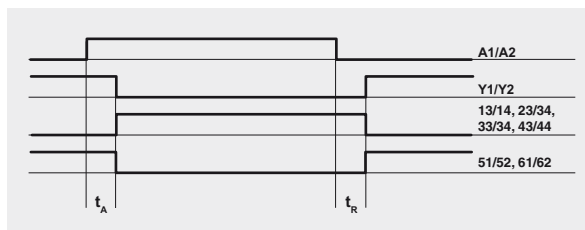

Legend:
 t_A : response time
 t_R : release time in absence of power supply

Internal block diagram

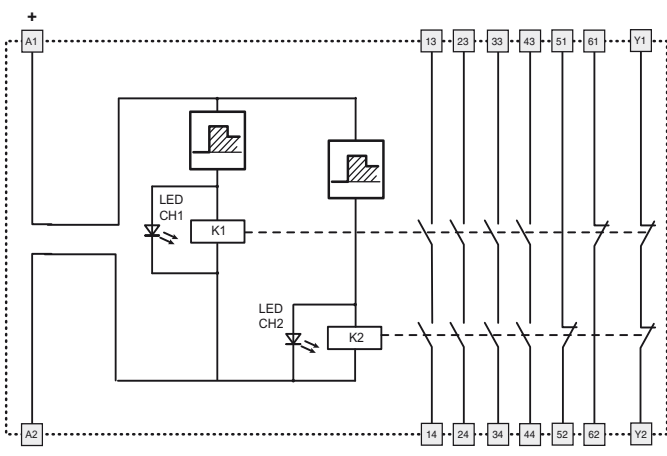

Input configuration

Single channel control

Double channel control

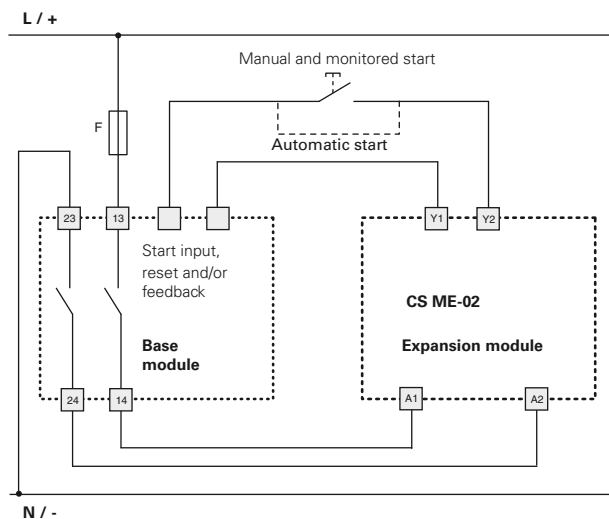
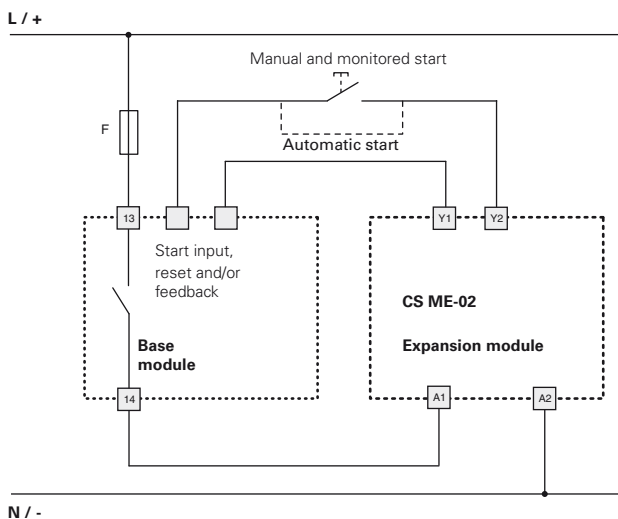

The diagram does not show the exact position of the terminals in the product

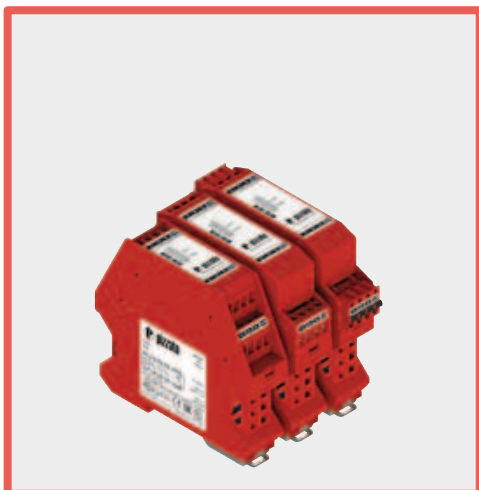

Expansion module with output contacts

Main features

- For safety applications up to SIL CL 3/PL e
- Module for semiconductor outputs (light barriers type 2 and 4)
- 2 OSSD inputs
- Reduced housing width of 22.5 mm
- Output contacts:
3 NO safety contacts,
1 NC feedback contact/EDM
- Supply voltage: 24 Vdc

Utilization categories

Alternating current: AC15 (50...60 Hz)

U_e (V) 230

I_e (A) 3

Direct current: DC13 (6 oper. cycles/min.)

U_e (V) 24

I_e (A) 4

Quality marks and certificates:



EC type examination certificate: IMQ CP 432 DM

UL approval: E131787

CCC approval: 2013010305640211

EAC approval: RU C-IT.AQ35.B.00454

Compliance with the requirements of:

Low Voltage Directive 2014/35/EU,

Machinery Directive 2006/42/EC,

EMC Directive 2014/30/EU

Technical data

Housing

Polyamide housing PA 66, self-extinguishing V0 acc. to UL 94

Protection degree:

IP40 (housing), IP20 (terminal strip)

Dimensions:

see page 296, design D

General data

SIL CL:

up to SIL CL 3 acc. to EN 62061

Performance Level (PL):

up to PL e acc. to EN ISO 13849-1

Safety category:

up to cat. 4 acc. to EN ISO 13849-1
(dependent on semiconductor outputs)

Safety parameters:

see page 349

Ambient temperature:

-25°C...+55°C

Mechanical endurance:

>10 million operating cycles

Electrical endurance:

>100,000 operating cycles

Pollution degree:

external 3, internal 2

Impulse withstand voltage (U_{imp}):

4 kV

Rated insulation voltage (U_i):

250 V

Overvoltage category:

II

Weight:

0.2 kg

Supply

Rated supply voltage (U_n):

24 Vdc

Max. DC residual ripple in DC:

10%

Supply voltage tolerance:

±15% of U_n

Power consumption DC:

< 2 W

Consumption at start:

< 3 W

Control circuit

Response time t_A:

< 40 ms

Release time t_{RI}:

< 15 ms

In compliance with standards:

EN 60204-1, EN ISO 13855, EN 1037, EN ISO 12100, EN ISO 13850, EN 60529,

EN 61000-6-2, EN 61000-6-3, EN 61326-1, EN 60664-1, EN 60947-1, EN ISO 13849-1,

EN ISO 13849-2, EN 62061, UL 508, CSA C22.2 n° 14-95

Output circuit

Output contacts:

3 NO safety contacts, 1 NC feedback contact

Contact type:

forcibly guided

Material of the contacts:

gold-plated silver alloy

Maximum switching voltage:

230/240 Vac; 300 Vdc

Max. current per contact:

6 A

Conventional free air thermal current (I_{th}):

6 A

Max. total current Σ I_{th}²:

36 A²

Minimum current:

10 mA

Contact resistance:

≤ 100 mΩ

External protection fuse:

4 A

Code structure

CS ME-03VU24

Connection type

V Screw terminals

M Connector with screw terminals

X Connector with spring terminals

Supply voltage

U24 24 Vdc

Stock items

CS ME-03VU24

Features approved by UL

Rated supply voltage (U_n): 24 Vac/dc; 50...60 Hz

Power consumption DC: < 2 W

Maximum switching voltage: 230 Vac

Max. current per contact: 6 A

Utilization category: C300

Notes:

- Use 60 or 75 °C copper (Cu) conductors, rigid or flexible, wire size 30-12 AWG.

- Tightening torque for terminal screws of 5-7 lb in.

- Only for 24 Vac/dc versions: power supply only with class 2 sources or with limited voltage and energy. (Supply from Remote Class 2 Source or limited voltage limited energy).



CS ME-03 expansion module

Pin assignment

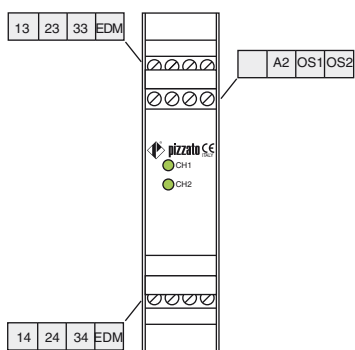

Function diagram

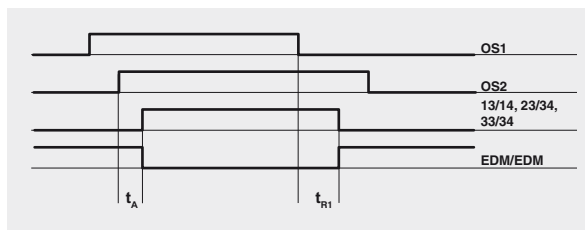

Legend:
 t_A : response time
 t_{R1} : release time

Internal block diagram

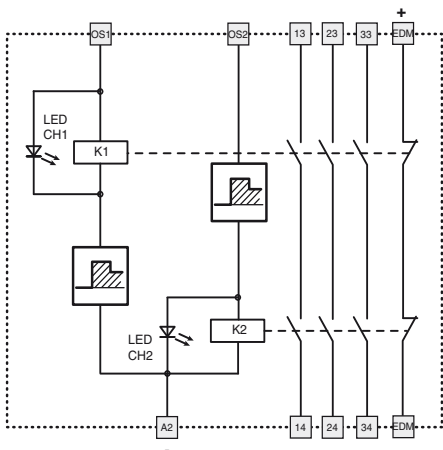

Application example on page 253.

Input configuration

Semiconductor outputs (e.g. light barriers)	
1 channel	2 channels

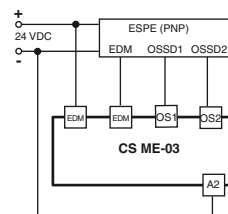
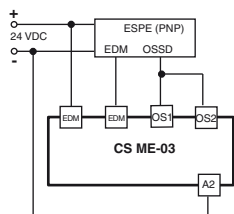

The diagram does not show the exact position of the terminals in the product

Items with code on **green** background are stock items

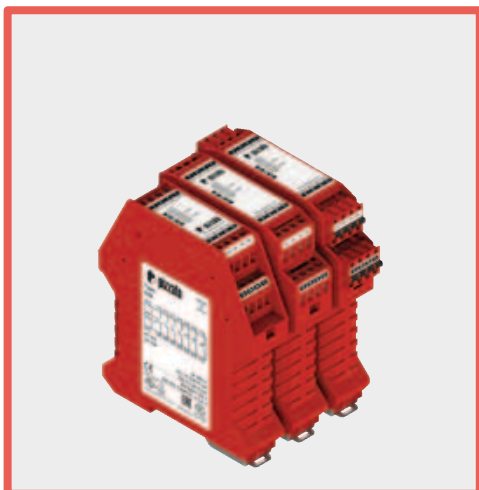

Expansion module with delayed output contacts at de-energizing

Main features

- For safety applications up to SIL CL 3/PL e
- Possibility of control with one or two channels
- 4 delay times 0.5 - 1 - 2 and 3 s
- Reduced housing width of 22.5 mm
- Output contacts:
 - 4 NO safety contacts,
 - 2 NC auxiliary contacts,
 - 1 NC feedback contact
- Supply voltage: 24 Vdc

Utilization categories

Alternating current: AC15 (50...60 Hz)

U_e (V) 230

I_e (A) 3

Direct current: DC13 (6 oper. cycles/min.)

U_e (V) 24

I_e (A) 4

Quality marks and certificates:



EC type examination certificate: IMQ CP 432 DM

UL approval: E131787

CCC approval: 2013010305640211

EAC approval: RU C-IT.A.35.B.00454

Compliance with the requirements of:

Low Voltage Directive 2014/35/EU,

Machinery Directive 2006/42/EC,

EMC Directive 2014/30/EU

Technical data

Housing

Polyamide housing PA 66, self-extinguishing V0 acc. to UL 94

Protection degree:

IP40 (housing), IP20 (terminal strip)

Dimensions:

see page 295, design A

General data

SIL CL:

up to SIL CL 3 acc. to EN 62061

Performance Level (PL):

up to PL e acc. to EN ISO 13849-1

Safety category:

up to cat. 4 acc. to EN ISO 13849-1

(see base module category)

Safety parameters: see page 349

Ambient temperature:

-25°C...+55°C

Mechanical endurance:

>10 million operating cycles

Electrical endurance:

>100,000 operating cycles

Pollution degree:

external 3, internal 2

Impulse withstand voltage (U_{imp}):

4 kV

Rated insulation voltage (U_i):

250 V

Overvoltage category:

II

Weight:

0.2 kg

Supply

Rated supply voltage (U_n):

24 Vdc

Max. DC residual ripple in DC:

10%

Supply voltage tolerance:

±15% of U_n

Power consumption DC:

< 2 W

Control circuit

Maximum resistance per input:

≤ 50 Ω

Response time t_Δ:

< 120 ms

Release time in absence of power supply t_R:

see Code structure

In compliance with standards:

EN 60204-1, EN ISO 13855, EN 1037, EN ISO 12100, EN ISO 13850, EN 60529,

EN 61000-6-2, EN 61000-6-3, EN 61326-1, EN 60664-1, EN 60947-1, EN ISO 13849-1,

EN ISO 13849-2, EN 62061, UL 508, CSA C22.2 n° 14-95

Output circuit

Output contacts:

4 NO safety contacts,
2 NC auxiliary contacts,
1 NC feedback contact

Contact type:

forcibly guided

Material of the contacts:

gold-plated silver alloy

Maximum switching voltage:

230/240 Vac; 300 Vdc

Max. current per contact:

6 A

Conventional free air thermal current (I_{th}):

6 A

Max. total current Σ I_{th}²:

64 A²

Minimum current:

10 mA

Contact resistance:

≤ 100 mΩ

External protection fuse:

4 A

Code structure

CS ME-20VU24-TF1

Connection type	
V	Screw terminals
M	Connector with screw terminals
X	Connector with spring terminals

Release time in absence of power supply (t _R)	
TF0.5	0.5 s fixed time
TF1	1 s fixed time
TF2	2 s fixed time
TF3	3 s fixed time

Features approved by UL

Rated supply voltage (U _n):	24 Vdc
Power consumption DC:	< 2 W
Maximum switching voltage:	230 Vac
Max. current per contact:	6 A
Utilization category	C300

Notes:

- Use 60 or 75 °C copper (Cu) conductors, rigid or flexible, wire size 30-12 AWG.
- Tightening torque for terminal screws of 5-7 lb in.
- Only for 24 Vac/dc versions: power supply only with class 2 sources or with limited voltage and energy. (Supply from Remote Class 2 Source or limited voltage limited energy).



CS ME-20 expansion module

Pin assignment

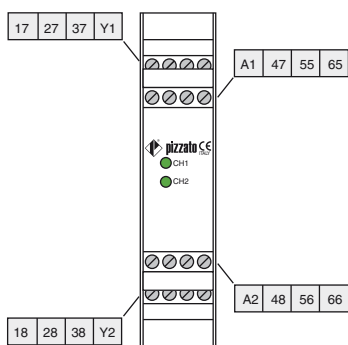

Function diagram

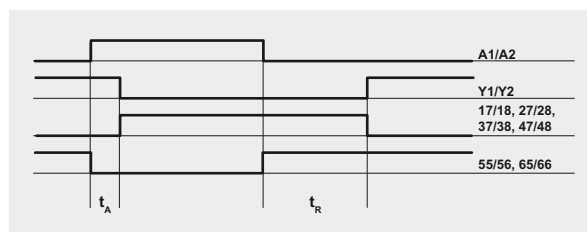

Legend:
 t_A : response time
 t_R : release time in absence of power supply (see "Code structure")

Internal block diagram

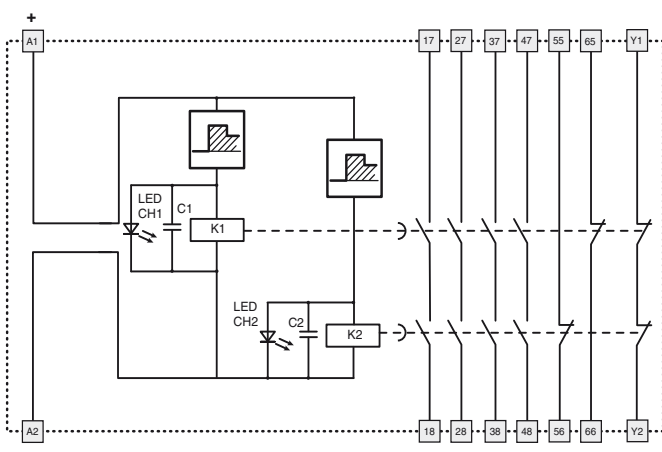

Input configuration

Single channel control

Double channel control

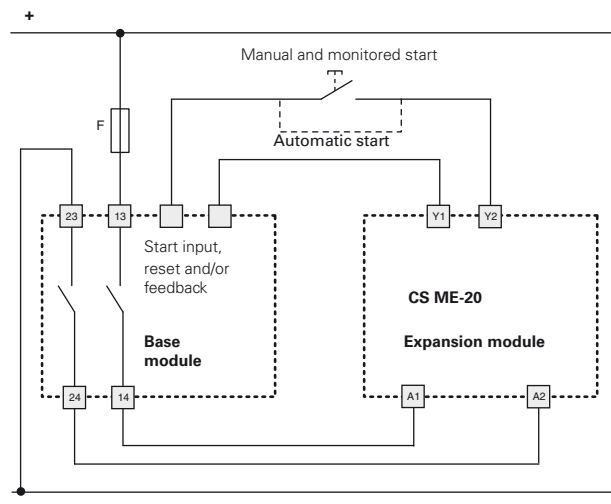
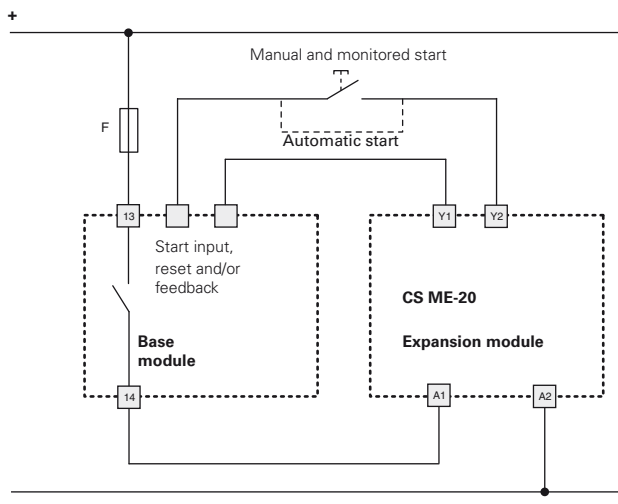

The diagram does not show the exact position of the terminals in the product



Expansion module with delayed output contacts at de-energizing

Main features

- For safety applications up to SIL CL 3/PL e
- Possibility of control with one or two channels
- Fixed or adjustable delay times
- 45 mm housing
- Output contacts:
 - 4 NO safety contacts,
 - 2 NC auxiliary contacts,
 - 1 NC feedback contact
- Supply voltage: 24 Vdc

Utilization categories

Alternating current: AC15 (50...60 Hz)

U_e (V) 230

I_e (A) 3

Direct current: DC13 (6 oper. cycles/min.)

U_e (V) 24

I_e (A) 4

Quality marks and certificates:



EC type examination certificate: IMQ CP 432 DM

UL approval: E131787

CCC approval: 2013010305640211

EAC approval: RU C-IT.AД35.B.00454

Compliance with the requirements of:

Low Voltage Directive 2014/35/EU,

Machinery Directive 2006/42/EC,

EMC Directive 2014/30/EU

Technical data

Housing

Polyamide housing PA 66, self-extinguishing V0 acc. to UL 94

Protection degree:

IP40 (housing), IP20 (terminal strip)

Dimensions:

see page 296, design C

General data

SIL CL:

up to SIL CL 3 acc. to EN 62061

Performance Level (PL):

up to PL e acc. to EN ISO 13849-1

Safety category:

up to cat. 4 acc. to EN ISO 13849-1 (see base module category)

Safety parameters:

see page 349

Ambient temperature:

-25°C...+55°C

Mechanical endurance:

>10 million operating cycles

Electrical endurance:

>100,000 operating cycles

Pollution degree:

external 3, internal 2

Impulse withstand voltage (U_{imp}):

4 kV

Rated insulation voltage (U_i):

250 V

Overtoltage category:

II

Weight:

0.4 kg

Supply

Rated supply voltage (U_n):

24 Vdc

Max. DC residual ripple in DC:

10%

Supply voltage tolerance:

±15% of U_n

Power consumption DC:

< 2 W

Control circuit

Maximum resistance per input:

≤ 50 Ω

Response time t_λ:

< 200 ms

Release time in absence of power supply t_R:

see Code structure

In compliance with standards:

EN 60204-1, EN ISO 13855, EN 1037, EN ISO 12100, EN ISO 13850, EN 60529,

EN 61000-6-2, EN 61000-6-3, EN 61326-1, EN 60664-1, EN 60947-1, EN ISO 13849-1,

EN ISO 13849-2, EN 62061, UL 508, CSA C22.2 n° 14-95

Output circuit

Output contacts:

4 NO safety contacts,
2 NC auxiliary contacts,
1 NC feedback contact

Contact type:

forcibly guided
gold-plated silver alloy

Maximum switching voltage:

230/240 Vac; 300 Vdc

Max. current per contact:

6 A

Conventional free air thermal current (I_{th}):

6 A

Max. total current Σ I_{th}²:

64 A²

Minimum current:

10 mA

Contact resistance:

≤ 100 mΩ

External protection fuse:

4 A

Code structure

CS ME-30VU24-TF1

Fixed or adjustable time

0	fixed time
1	adjustable time

Connection type

V	Screw terminals
M	Connector with screw terminals
X	Connector with spring terminals

Release time in absence of power supply (t_R)

TF1	1 s fixed time (CS ME-30 only)
...
TF12	12 s fixed time (CS ME-30 only)
	Time adjustable from
TS12	1 to 12 s in increments of 1 s (CS ME-31 only)

Features approved by UL

Rated supply voltage (U _n):	24 Vdc
Power consumption DC:	< 2 W
Maximum switching voltage:	230 Vac
Max. current per contact:	6 A
Utilization category	C300

Notes:

- Use 60 or 75 °C copper (Cu) conductors, rigid or flexible, wire size 30-12 AWG.
- Tightening torque for terminal screws of 5-7 lb in.
- Only for 24 Vdc/dc versions: power supply only with class 2 sources or with limited voltage and energy. (Supply from Remote Class 2 Source or limited voltage limited energy).



CS ME-30 / CS ME-31 expansion module

Pin assignment

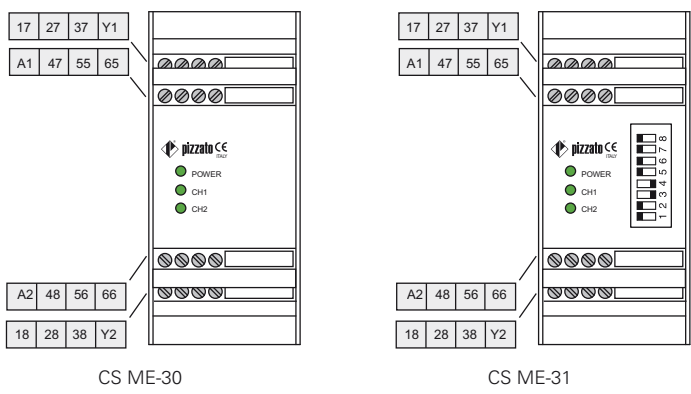

Function diagram

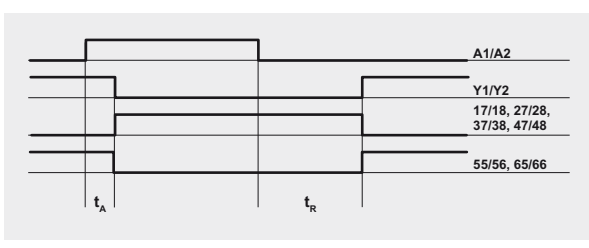

Legend:
 t_A : response time
 t_R : release time in absence of power supply (see "Code structure")

Release time selection t_R (CS ME-31 only)

DIP SWITCH		t_R (s)
ON	OFF	1
ON	OFF	2
ON	OFF	3
ON	OFF	4
ON	OFF	5
ON	OFF	6
ON	OFF	7
ON	OFF	8
ON	OFF	9
ON	OFF	10
ON	OFF	11
ON	OFF	12

Internal block diagram

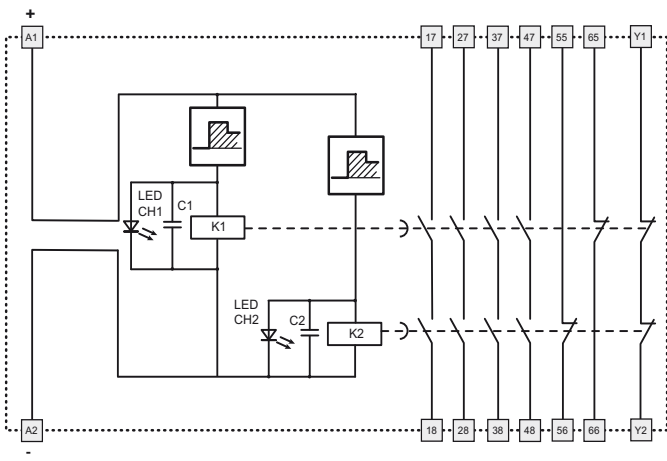

Input configuration

Single channel control

Double channel control

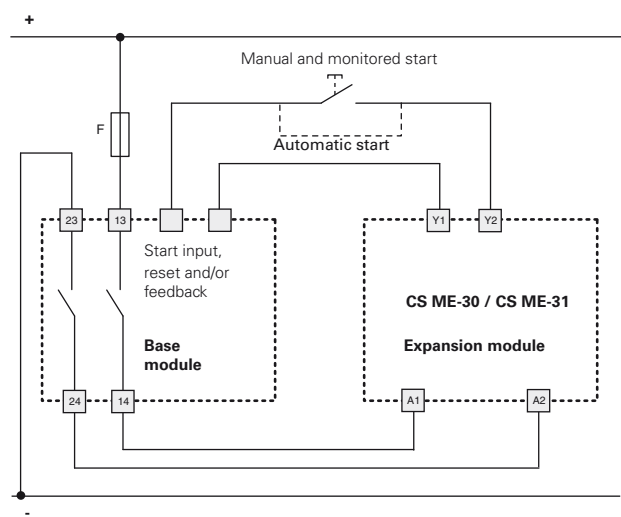
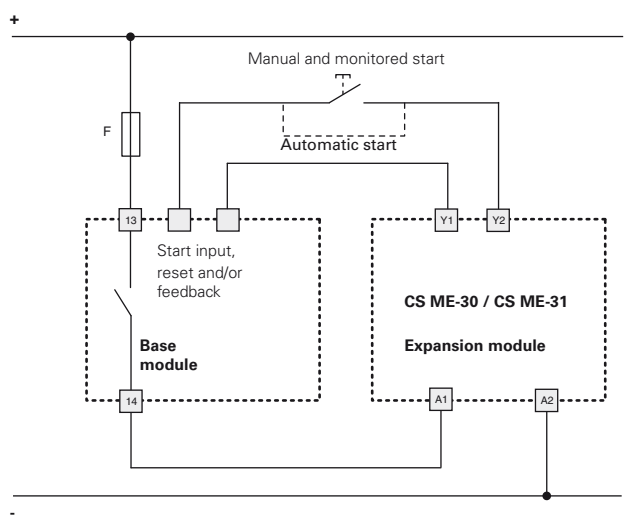

The diagram does not show the exact position of the terminals in the product